

14-B, SIPCOT Industrial Complex,
Pudukkottai-622 002 Tamil Nadu.

Phone : +91-4322-244441/42
Fax : +91-4322-244443
Mobile: +91-9840032218
E-Mail : laybond@gmail.com

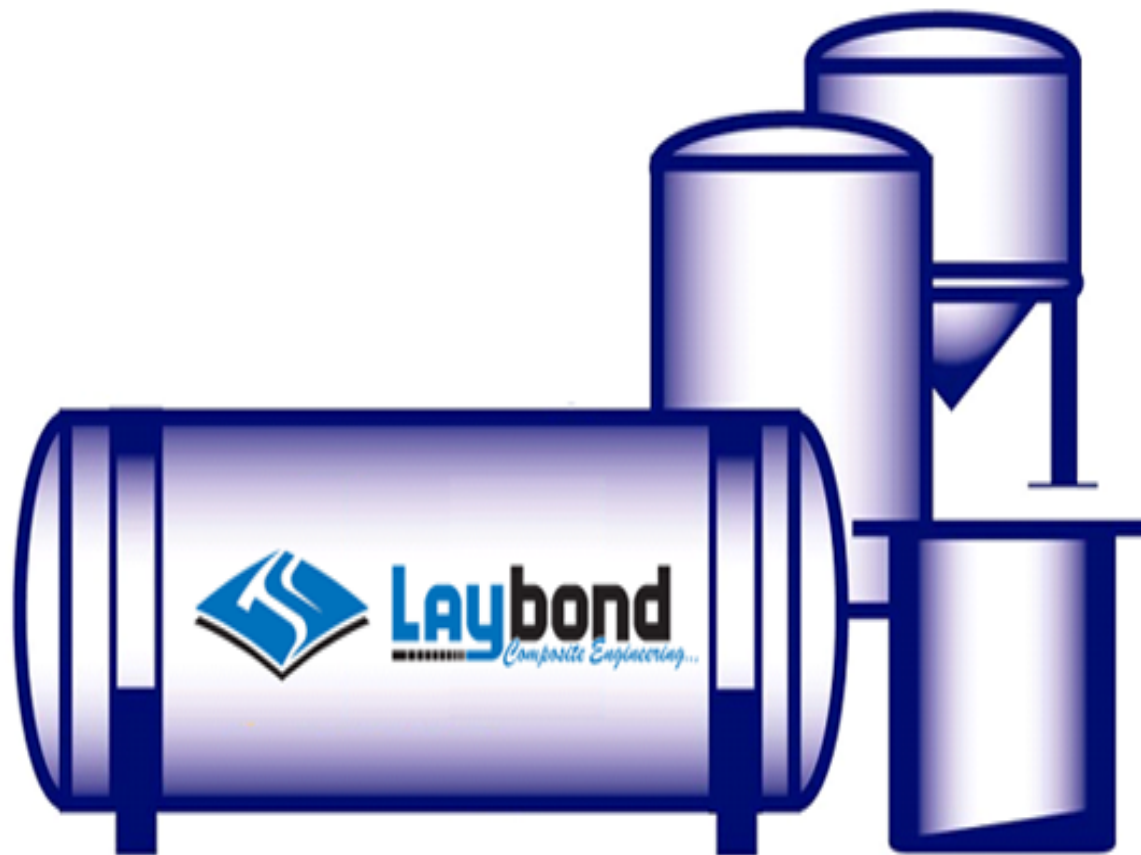

OPERATION & MAINTENANCE INSTRUCTION MANUAL



www.laybond.co.in



TABLE OF CONTENTS

OPERATION AND MAINTENANCE INSTRUCTIONS

GENERAL	Page 2
TANK CLEANING	Page 2
AIR LOADING	Page 3
MANHOLE BOLTING (20" & 24")	Page 4
MANHOLE BOLTING (30" & 36")	Page 5
FLANGE BOLTING (1" - 14")	Page 6
FLANGE BOLTING (16" - 24")	Page 7
FLANGE LOADS	Page 8
TANK USAGE	Page 9

OPERATION AND MAINTENANCE INSTRUCTIONS

Because of FIBERGLASS REINFORCED PLASTIC tanks unique, physical and structural characteristics; They are flexible, lightweight, corrosion resistant, and stronger than tanks made of other plastic materials.

Care, however, should be taken to follow the Handling and Installation instructions. Once the tank has been properly installed and placed in service, LAYBOND recommends regular routine inspections as a part of your preventative maintenance program.

The care and operation of FRP vessels rely mostly on common sense. To maximize trouble free service, LAYBOND recommends:

1. Inspect your vessel thoroughly upon receipt.
2. Follow the Handling and Installation instruction.
3. Wash your vessel thoroughly w/detergent and rinse before putting in service (see FDA Requirements)

AFTER THE TANK IS PUT IN SERVICE:

1. Keep the vessel clean.
 - a. It will remain more aesthetically pleasing.
 - b. If the tank is ever damaged, it will be evident.
2. Make a visual tank inspection inside and outside the tank every 6-12 months.

TANKS FOR FOOD APPLICATION:

LAYBOND tanks will comply with U.S. Food, Drug and Cosmetic Act, as amended and applicable FDA regulations (21 cfr 177.2420). These tanks may be used as components intended for repeated use in contact with food, subject to certain limitations described in that regulation.

LAYBOND tanks are chemically acceptable in processing or storage areas for contact with meat or poultry food products prepared under federal inspection and used at temperatures below 180° F. This acceptance has been given by the United States Department of Agriculture.

Prior to shipping your tank, LAYBOND applies a (4) hour heat cure followed by a water rinse to the tank interior.

After installation and before your tank is put into service, attention to the following procedures is important to achieve FDA compliance:

1. after tank installation, steam-treat or steep tank with hot water for 8-16 hours at 160° – 180° F. This should remove all residual styrene from the laminate surface.
2. Wash the tank thoroughly with detergent and rinse it thoroughly.
3. Check state and local regulations for required compliance in addition to the above recommendations.

OPERATION AND MAINTENANCE INSTRUCTIONS

AIR LOADING

"Tanks are often filled with liquids from tanker trucks by pressurizing the headspace above the liquid within the tanker with compressed air to force tanker contents into the receiving tank. This is most typically done when the liquid being transferred is a corrosive chemical, which could damage a pump. Although such a procedure eliminates the need for a pump, a possibility does exist that the pressurized air within the tanker will follow the liquid into the receiving tank, and destroy the tank, due to excessive pressure.

Generally speaking, the tanker is connected to the receiving tank by a hose. The compressed air pushing down on the liquid forces the liquid through the hose and into the receiving tank. The frictional resistance offered by the hose and the fitting limits the maximum velocity of the liquid moving through the hose to a reasonable value. The air displaced by the liquid entering the tank escapes through the normal vent provided on the tank.

However, when the last of the liquid passes through the hose, the compressed air within the tanker rushes through the hose at an extremely high velocity, because this air does not meet significant frictional resistance in the hose, as the liquid does. This air enters the headspace in the receiving tank and expands with almost explosive speed and force. The conventional tank vent cannot relieve this excessive pressure within the tank. When the pressure within the receiving tank exceeds that for which the tank is designed, either the tank head blows off or some other portion of the tank ruptures.

Preferably, the person operating the tanker will interrupt the liquid flow before the last of the liquid leaves the tanker, preventing the compressed air from entering the tank. However, through inattention or carelessness, the operator will occasionally forget to interrupt the liquid at the "appropriate time"...RESULT...POSSIBLE TANK FAILURE."

The quoted description above is the possible occurrence when the tank is air loaded...IMPROPERLY; proper procedure requires that the operator interrupt the liquid at the appropriate time. PROPER PROCEDURE WILL NOT CAUSE TANK FAILURE.

To guard against tank failure when the tank is air loaded, opening the manhole cover is suggested. This precaution, if the tank is air loaded improperly, does NOT eliminate the possibility of tank failure...but it may lessen the possibility.

TO ELIMINATE TANK FAILURE DUE TO IMPROPER AIR LOADING: A. BUILD A PRESSURE VESSEL, OR

B. ELIMINATE THE POSSIBILITY OF THE AIR PAD PRESSURE IN THE TANKER FROM REACHING THE TANK INTERIOR BY:

1. Suspending the fill line above the man way (i.e. line is not to enter tank), OR...
2. Monitoring a flow meter to determine when the tanker will be empty, OR...
3. Install a "No-Flow" switch in tandem with a control valve.

Note: LAYBOND recommends consulting with a reputable firm in reference to flow meters and no flow switches. If you have any questions or special circumstances that require discussion, please feel free to contact us at... +91-9840032218

OPERATION AND MAINTENANCE INSTRUCTIONS

MANHOLE BOLTING SEQUENCE

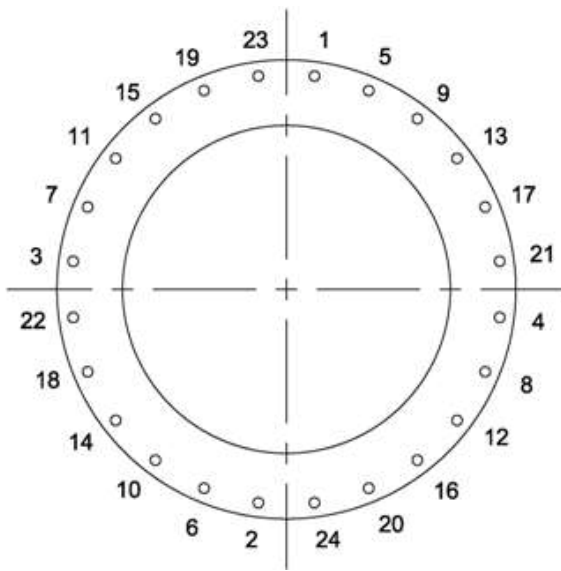

20" Side Manhole

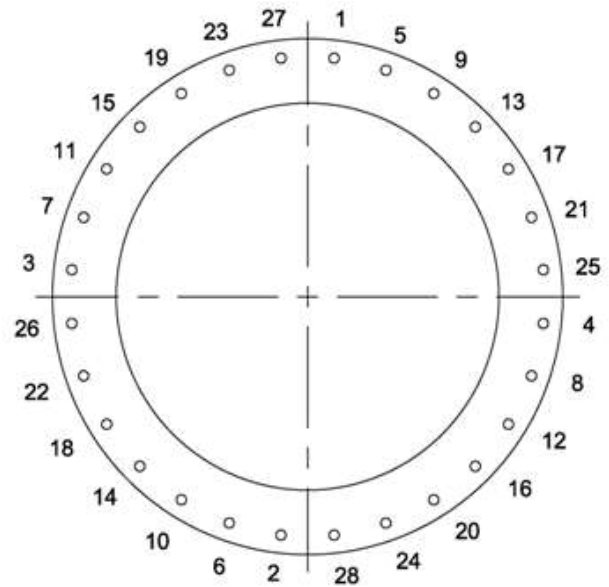

24" Side Manhole

Drawings not to scale

Side Manhole Maximum Bolt Torque

Manhole PSI Rating (See Drawing)								
Diameter	5	10	15	20	25	30	35	40
20"	16 ft. lbs.	20 ft. lbs.	20 ft. lbs.	20 ft. lbs.	20 ft. lbs.	20 ft. lbs.	20 ft. lbs.	20 ft. lbs.
24"	16 ft. lbs.	20 ft. lbs.	20 ft. lbs.	20 ft. lbs.	20 ft. lbs.	20 ft. lbs.	20 ft. lbs.	20 ft. lbs.

OPERATION AND MAINTENANCE INSTRUCTIONS

MANHOLE BOLTING SEQUENCE

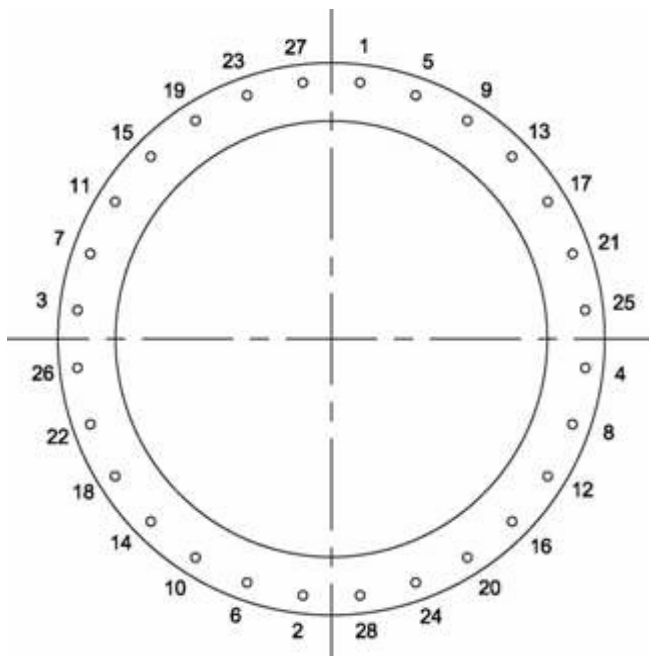

30" Side Manhole

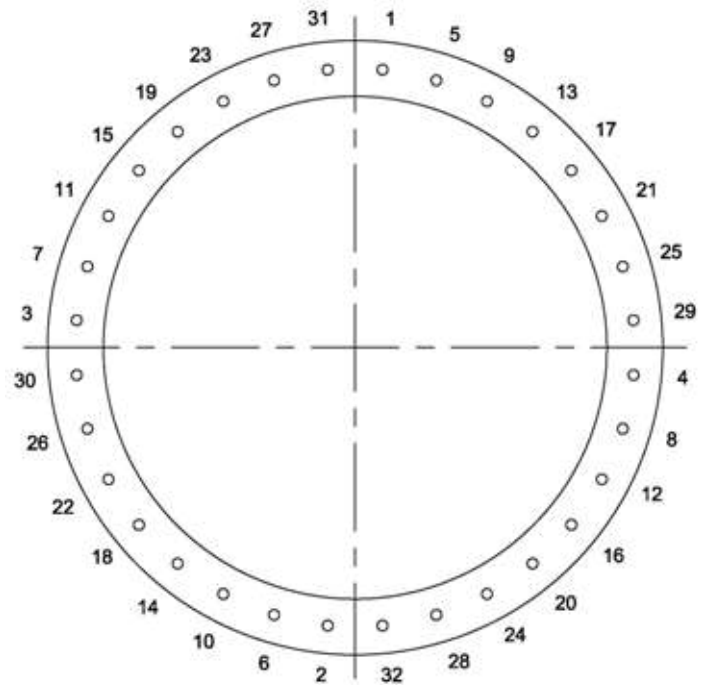

36" Side Manhole

Drawings not to scale

Side Manhole Maximum Bolt Torque

Manhole PSI Rating (See Drawing)								
Diameter	5	10	15	20	25	30	35	40
30"	25 ft. lbs.	43 ft. lbs.	43 ft. lbs.	43 ft. lbs.	43 ft. lbs.	43 ft. lbs.	43 ft. lbs.	43 ft. lbs.
36"	25 ft. lbs.	43 ft. lbs.	43 ft. lbs.	43 ft. lbs.	43 ft. lbs.	43 ft. lbs.	43 ft. lbs.	43 ft. lbs.

OPERATION AND MAINTENANCE INSTRUCTIONS

FLANGED NOZZLE BOLTING SEQUENCE

CAUTION: A flange spacer **MUST BE USED** when bolting FRP flanges to raised face flanges. Use only full face gaskets. Do **NOT** over torque flange bolts.

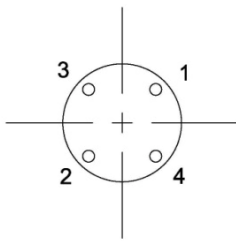

4 Bolt

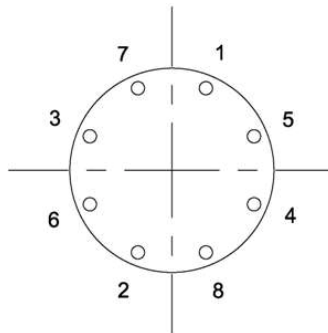

8 Bolt

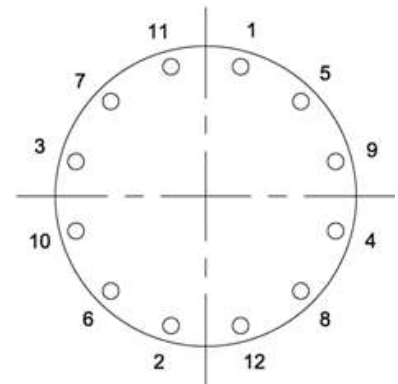

12 Bolts

Drawings not to scale

Flanged Nozzle PSI Rating & Maximum Torque

Diameter	PSI Rating	Maximum Torque
1"	125	14 ft. lbs.
1-1/2"	125	20 ft. lbs.
2"	125	41 ft. lbs.
2-1/2"	125	43 ft. lbs.
3"	125	43 ft. lbs.
4"	125	43 ft. lbs.
6"	100	77 ft. lbs.
8"	50	77 ft. lbs.
10"	50	98 ft. lbs.
12"	50	125 ft. lbs.
14"	25	105 ft. lbs.

OPERATION AND MAINTENANCE INSTRUCTIONS

FLANGED NOZZLE BOLTING SEQUENCE

CAUTION: A flange spacer **MUST BE USED** when bolting FRP flanges to raised face flanges. Use only full face gaskets. Do **NOT** over torque flange bolts.

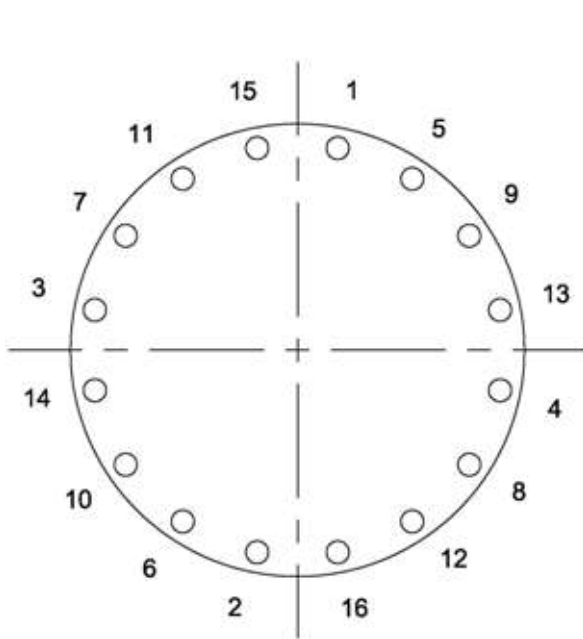

16 Bolt

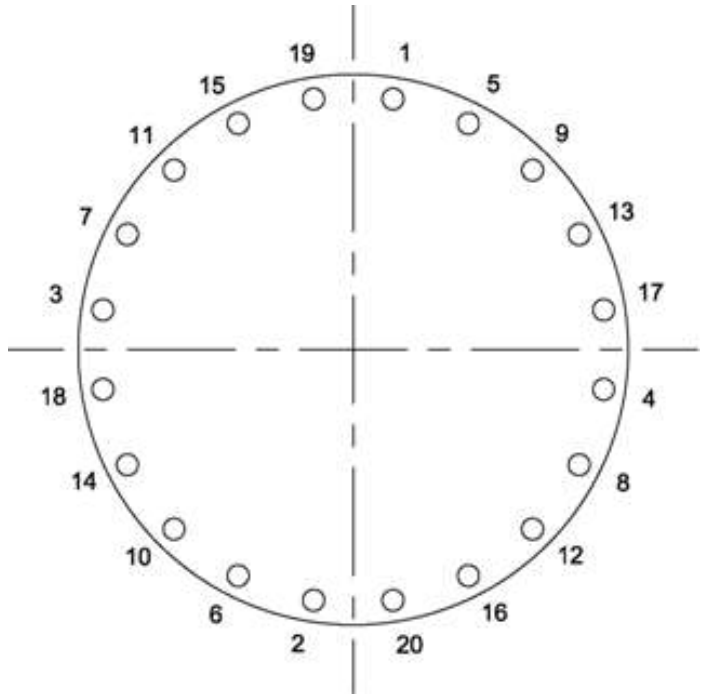

20 Bolts

Drawings not to scale

Flanged Nozzle PSI Rating & Maximum Torque

Diameter	PSI Rating	Maximum Torque
16"	25	102 ft. lbs.
18"	25	135 ft. lbs.
20"	25	131 ft. lbs.
24"	25	205 ft. lbs.

OPERATION AND MAINTENANCE INSTRUCTIONS

Flanged Nozzle Allowable Loads without Gussets

Size	A	B	C
1	100 LBS.	50 FT./LBS.	100 LBS.
1-1/2	100 LBS.	100 FT./LBS.	100 LBS.
2	100 LBS.	100 FT./LBS.	100 LBS.
3	100 LBS.	100 FT./LBS.	100 LBS.
4	100 LBS.	100 FT./LBS.	100 LBS.
6	100 LBS.	100 FT./LBS.	100 LBS.
8	100 LBS.	100 FT./LBS.	100 LBS.
10	100 LBS.	100 FT./LBS.	100 LBS.
12	100 LBS.	100 FT./LBS.	100 LBS.

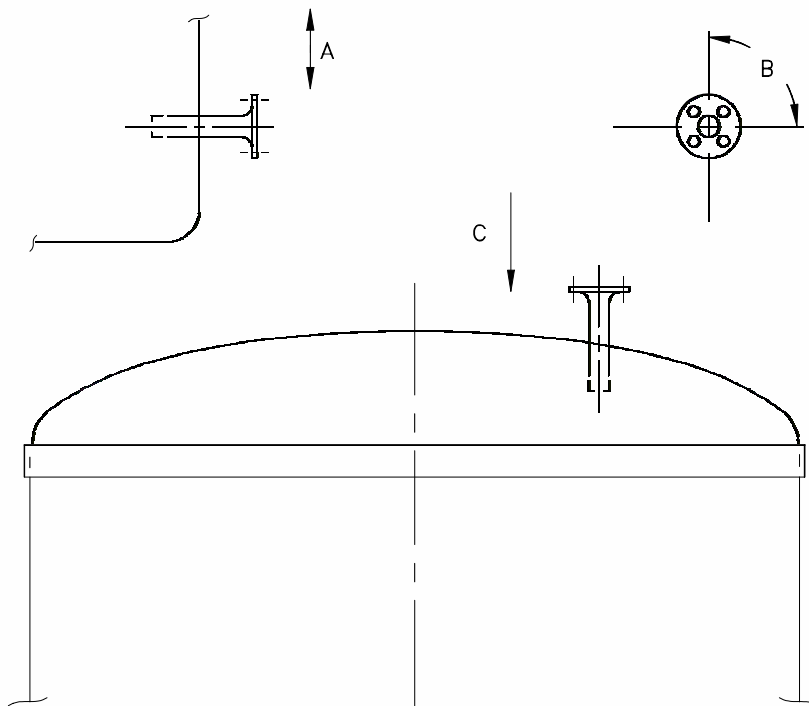

OPERATION AND MAINTENANCE INSTRUCTIONS

TANK USAGE

This tank has been sold for a specific chemical storage application. Before changing the chemical environment, consult with LAYBOND (your warranty may be void without written authorization from LAYBOND)

LAYBOND standard tanks are NOT designed for pressure or vacuum other than liquid head. Be sure tanks are properly vented to avoid accidental pressure or vacuum.